

Polyphase kWh Electricity Meter

Model Type: 5192B



USER MANUAL

Issue 1.0

Contents

1	Introduction	2
1.1	Purpose	2
2	Definitions	2
2.1	References	2
3	Meter Overview	3
4	Operational Requirements	3
4.1	Measurement	3
4.2	Total kWh Register	3
4.3	Total kVAh Register	3
4.4	Reverse Energy	3
4.6	Meter Memory	4
4.7	Anti-creep	4
4.8	Power Supply	4
4.9	Phase Indication	4
5	User Interfaces	4
5.1	Pulse Output	4
5.2	Optical Interface	5
5.3	Inductive Serial Data Port	5
6	Installation	5
6.1	Wiring	5
7	Technical Summary	6

1 Introduction

1.1 Purpose

This manual covers the Operation and Installation Instructions for the Polyphase, Single Rate Credit Meter with Pulse Output, the 5192B. A Polyphase, Multi Rate Credit Meter with Pulse Output is also available, the 5192F.

2 Definitions

BS : British Standard

IEC: International Electrotechnical Commission

SI : Statutory Instruments

kWh : Kilo Watt Hours

RTC : Real Time Clock

LCD : Liquid Crystal Display

LED : Light Emitting Diode

HHU : Hand-Held Unit

CMI : Common Modular Interface

mS : Milli-Second

2.1 References

1. BS EN61036 : 1996 : Alternating current static watt-hour meters for active energy. (classes 1 & 2)
2. BS5685 : 1979 : Part 1 : Specification class 0.5, 1.0 and 2.0 Single phase and Polyphase, single rate and multi-rate watt-hour meters.
3. IEC1268 : 1996: Alternating current static var-hour meters for reactive energy. (classes 2 & 3)
4. IEC1038 : 1993 : Time switches for tariff and load control.
5. IEC1107 : Data Exchange for Meter Reading, Tariff and Load Control. Direct Local Exchange.
6. SI1566 : 1998 : The Meters (Certification) Regulations 1998;

3 Meter Overview

The meter is a whole current credit meter, capable of measuring kWh and kVArh, type approved to BSEN61036: 1996 class 1.0 for kWh and IEC1268: 1996 class 2.0 for kVArh. The meter also has a certification life of 15 years and has 3 measuring elements capable of being configured as 3 phase 4 wire, 3 phase 3 wire, 2 wires of 3 phases, 1 wire of 2 phases or single phase of 3 wires. A LCD shows all the meter's data and phase condition.

4 Operational Requirements

4.1 Measurement

The Meter is a 220 / 380 Vac - 240 / 415 Vac per phase, 50 Hz, 20 - 120 Amp Polyphase Credit Meter. It contains 3 independent measuring elements allowing consumed energy to be measured in up to 4 wires. The meter measures and registers kWh to class 1.0 accuracy and kVArh to class 2.0 accuracy. There are 2 red LED's mounted on the front panel of the meter, pulsing at a rate of 1,000 pulses per kWh and kVArh measured in all 3 elements for energy registration.

4.2 Total kWh Register

The total kWh measured are stored internally to 3 decimal places. The total kWh is displayed on the meter to a maximum of 2 decimal places unless programmed via the Flag Port (see User Interfaces) to 3 decimal places for testing purposes.

- The Total kWh register range is 000000.000 - 999999.999 kWh

4.3 Total kVArh Register

The total kVArh measured are stored internally to 3 decimal places. The total kVArh is displayed on the meter to a maximum of 2 decimal places unless programmed via the Flag Port (see User Interfaces) to 3 decimal places for testing purposes.

- The Total kVArh register range is 000000.000 - 999999.999 kVArh

4.4 Reverse Energy

Reverse Energy is detected if export energy greater than 10 amps is measured for more than 10 seconds on any one of the 3 phases. If reverse energy is detected, the display alternates between a Reverse Energy Detected message and the default display.

4.5 Reverse Energy Register

The reverse kWh consumed by the meter are stored internally to 3 decimal places, but only displayed to a maximum of 2 decimal places.

- The Reverse kWh register range is 000000.000 - 999999.999 kWh

4.6 Meter Memory

All of the meter's data is recorded in a Ferro-electric Random Access Memory (FRAM) under the control of the microprocessor. All the kWh registers are stored in the FRAM and are updated every 1/100th of a kWh. The FRAM is guaranteed for a minimum of 10,000,000,000 write cycles.

4.7 Anti-creep

Below starting current, the meter enters into an anti-creep mode. In this state the meter registration LED's are permanently lit and the registers do not increment. The LED's remains lit until the meter current is increased in either the forward or reverse direction beyond the starting current.

4.8 Power Supply

The power supply for the meter electronics is derived from all 3 phases to neutral. The meter will continue to operate in the event of a loss of any one or two phases.

Rated Voltage:	220 / 380 Vac - 240 / 415 Vac
Operating Voltage Range:	+15% to -20%
Current Range:	5 to 120 Amps
Frequency:	50Hz
Power Burden:	Less than 2 watts

4.9 Phase Indication

The LCD gives phase indication using the legends 1,2,3 on the bottom of the display. Phase failure is indicated by non-illumination of the corresponding legend.

5 User Interfaces

5.1 Pulse Output

The meter has an optically isolated, voltage free open collector Pulse Output that is factory configured as follows:-

Output type:	Open collector
Max. Voltage:	24Vdc.
Max Power:	150mW
Pulse duration:	Configurable to between 20 and 500 mS
Pulses/kWh:	Configurable to between 1 and 1000

In situations where the pulses are to be collected and measured by a BMS system it is possible to reconfigure the **pulse duration & pulses/kWh** through the IEC 1107 port. **Software** and **Data Probes** for this purpose are available at an additional cost.

5.2 Optical Interface

In addition to re-programming the meter's factory set configuration (as described above) the Optical Interface or FLAG port can also be used for data collection via a hand-held Psion unit.

5.3 Inductive Serial Data Port

The meter incorporates an Inductive Serial Data Port, which will transmit all the information within the meter through the meter case. The data transmitted is generally in accordance with the CMI specification and can be received by any module fitted with a suitable receiver placed adjacent to the transmitter outside the case (there is no physical connection).

6 Installation

6.1 Wiring

As per the wiring diagram shown below. Terminal arrangement conforms to BS5685, Part1, 1985.

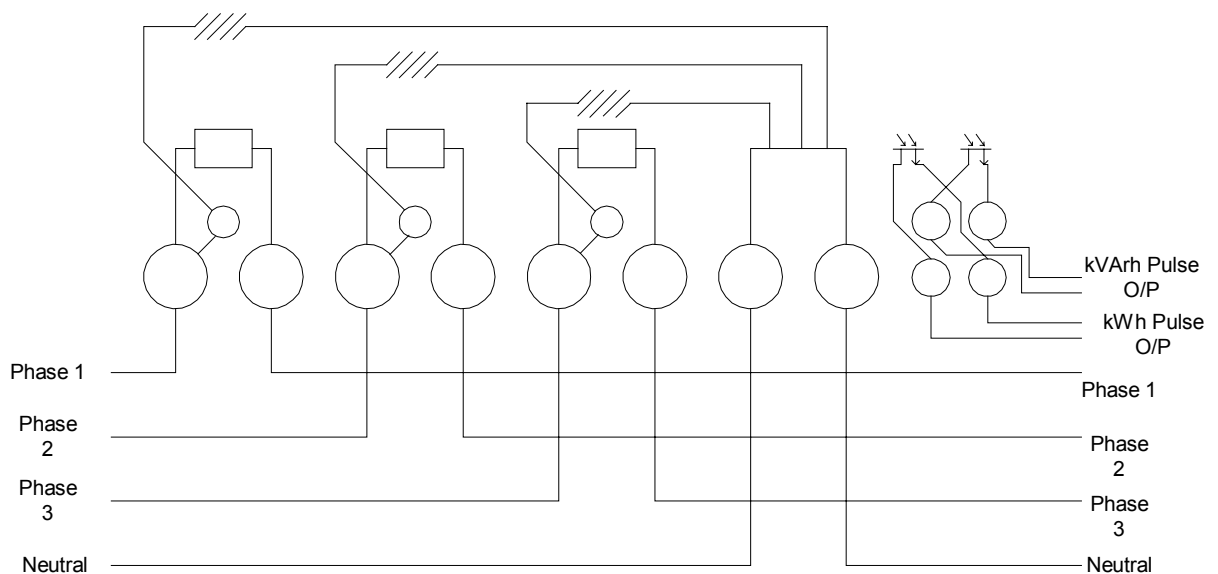

7 Technical Summary

System Voltage:	Three element meters	240Vac Phase to Neutral 230Vac Phase to Neutral 220Vac Phase to Neutral
	Supply variation	+15% to -20%
Current:	Direct connection	20 - 120A Ib/Imax
Pulse Output:	Meets IEC62053-13: 1998, Class B	
Burdens:	Voltage Circuit @ 230Vac	<2W <10VA
	Current Circuit @ Ib	<0.5VA @ Imax <1VA
Supply Frequency:	Nominal	50Hz
	Frequency Variation	+/- 5%
Temperature Range:	Limit operating range	-20°C to 55°C
	Storage range	-25°C to 70°C
	Service life	20 Years
Current Rating:		120A
Dimensions (mm):	Standard Terminal Cover	H 172 x W 168 x D 57